



Reflux 819

Pressure regulator

Classification and Area of Application

REFLUX 819 is a downstream pressure regulator, pilot controlled, for medium and high pressure applications.

It is particularly suitable for use within the framework of installations for the distribution of natural gas, as well as for supply networks for civil and industrial use.

The accuracy of the regulated pressure, the high Range Ability ratio, together with the fast adaptation to changes in the operating conditions, even in the presence of abrupt changes in the flow rate, make the regulator **REFLUX 819** particularly suitable for use in gas supply installations of electric power generation stations (Turbogas).

The **Reflux 819** regulator, is classified according to the European standard **EN 334**, as a regulator which reacts in closure (**Fail to Close**).

It is truly a **TOP ENTRY** design, which confers to the regulator management advantages, for example the ability to perform full maintenance without uninstalling it from the connection pipe.

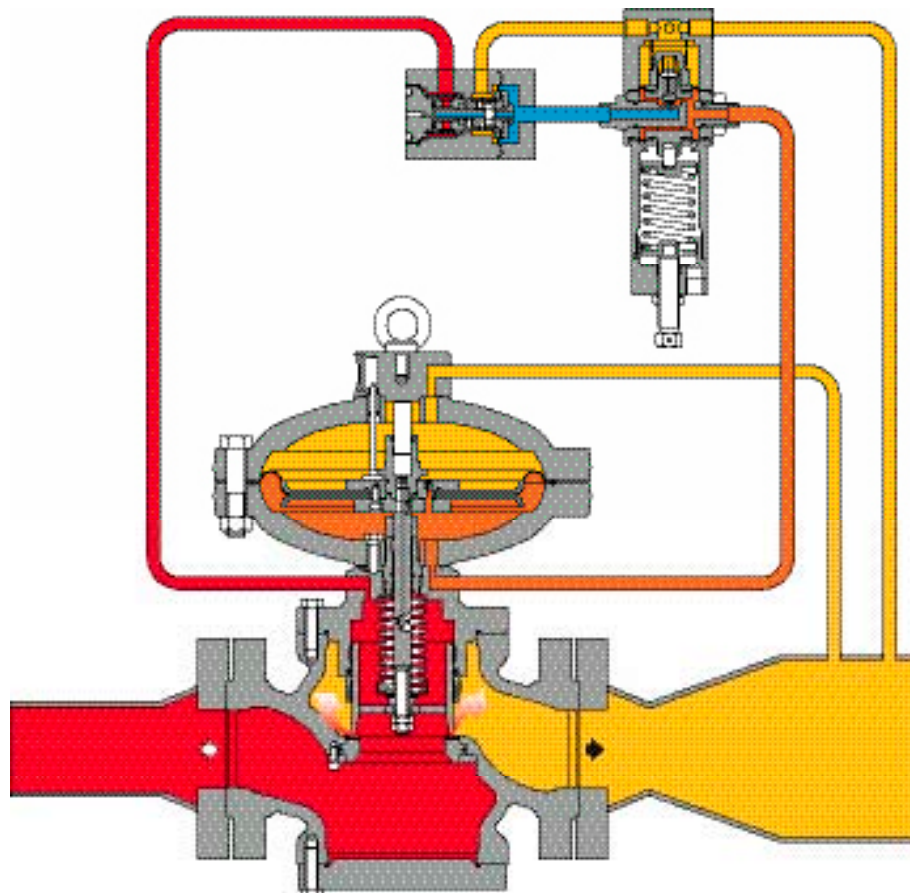

Fig.1

REFLUX 819 - Basic Version

FEATURES

Functional features:*

■ Maximum inlet pressure:	Up to 1479 PSIG (102 bar)
■ Range of downstream pressure:	from 4.35 PSIG (0.3) bar to 1.073 PSIG (74 bar) depending on installed pilot (see Pilot section).
■ Minimum differential pressure:	7.25 PSIG (0.5 bar)
■ Minimum ambient temperature:	Execution up to - 40°F (-40°C),
■ Maximum ambient temperature:	140°F (+60°C)
■ Inlet gas temperature:	Up to -4°F - 140°F (-20°C + 60°C),
■ Accuracy class AC:	Up to 1
■ Lock-up pressure class SG:	Up to 2.5

Design features:

■ Nominal dimensions DN:	1" (25); 2" (50); 3" (80); 4" (100); 6" (150); 8" (200); 10" (250"); 12" (300).
■ Flanged connections:	Class 150-300-600 RF or RTJ, according to ANSI B16.5 and PN 16/40 according to UNI 2282 or DIN 2263, (ISO 7005).

Materials:**

■ Body:	Cast steel ASTM A 352 LCC for classes ANSI 600 and 300; Cast steel ASTM A 216 WCB for classes Ansi 150 and PN 16/40.
■ Head covers:	ASTM A 350 LF2 forged steel
■ Stem:	AISI 416 stainless steel
■ Plug:	ASTM A 350 LF2 Nickel coated on sealing surface
■ Seat:	Nitril Rubber Vulcanized on a metal support
■ Diaphragm:	Rubberized canvas (performed by hot-pressing process).
■ Sealing ring:	Nitril rubber
■ Connection fittings:	In zinc-plated carbon steel according to DIN 2353; Stainless steel on request.

REMARK: * Different functional features available on request.
** The materials indicated above refer to the standard models.
Different materials can be provided according to specific needs.

Cg, KG and K1 coefficient

Nominal diameter								
Millimeters	25	50	80	100	150	200	250	300
Inches	1"	2"	3"	4"	6"	8"	10"	12"
Cg flow coefficient	575	2220	4937	8000	16607	25933	36525	55000
KG flow coefficient	605	2335	5194	8416	17471	27282	38425	52280
K1 body shape factor	106.78	106.78	106.78	106.78	106.78	106.78	106.78	106.78
								Tab.1

For sizing formulas refer to www.fiorentini.com/sizing

Pilots System

The operation of the regulator **REFLUX 819** is assured by a piloting system consisting, as basic option, of two separate devices: the **Preregulator** and the **Pilot**.

Preregulator

The following models are available:

R14/A: With self-adjusted calibration, providing a self-incremental feeding pressure to the pilot depending on the desired regulation pressure. It is equipped with a built-in filter and it is fed by the upstream gas.

R42/A – R44/A – R45/A: equipped with built-in filter on the gas inlet connection (upstream gas), with manually adjustable calibration.

Pilot

Reflux 819 regulators are equipped with series **200 pilot**.

The available models, according to the pressure to be regulated, are:

- **204/...**Outlet pressure control range from 4.35 to 623 PSIG (0,3 to 43) bar (with different setting springs),
- **205/...**Control range from 290 to 870 PSIG (20 to 60) bar (with different setting springs),
- **207/...**Control range from 595 to 1073 PSIG (41 to 74) bar (with different setting springs).

Pilots can be adjusted manually, in the field, or remotely to change the regulated pressure from far away. In the different cases, in order to identify them properly, they take the following suffixes:

- **.../A** Manual setting in place
- **.../D** Electric/Electronic remote setting control
- **.../CS** Pneumatic remote setting control
- **.../F.I.O.** Smart unit for remote setting, monitoring flow limitation and indirect flow measurement

MODULARITY AND ACCESSORIES

The project of **REFLUX 819** regulator has been designed with a high degree of modularity that allows to incorporate, within the basic regulator, alternative devices and additional accessories. These can also be added to a basic regulator at a later time, with no need to change the existing assembly piping connections.

Incorporated Silencer DB/819

The silencer **DB/819** allows absorbing the noise that is generated in the pressure regulator during the lamination process. Its great efficiency is due to the fact that noise absorption takes place at the same point where it is generated, thus preventing its propagation.

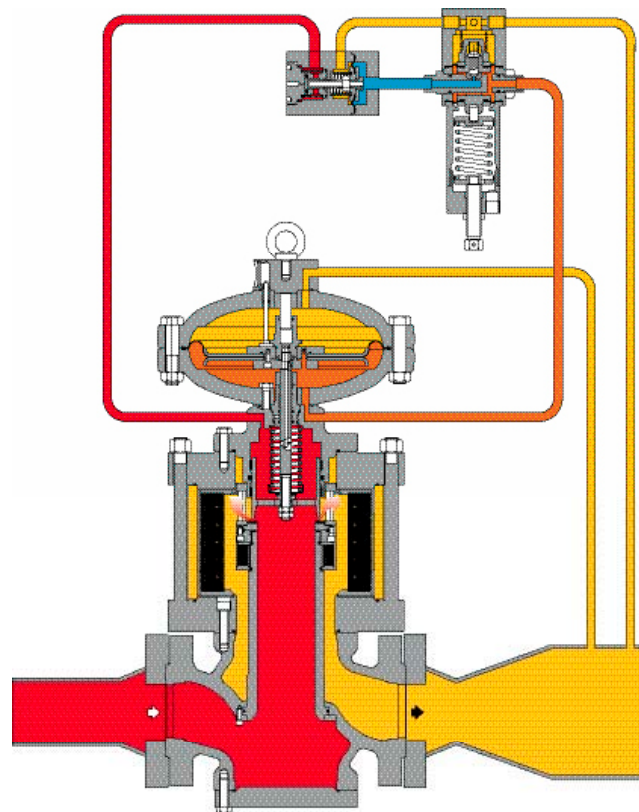

Fig.2

REFLUX 819 - With incorporated silencer

This mechanical solution allows to still have the possibility of incorporating in the basic regulator, besides the silencer, also the slam-shut valve or the monitor.

With the application of the silencer **DB/819** the Cg and KG valve coefficients are 5% lower than the corresponding basic regulator.

Slam shut device model SB/82 o HB/97

Slam shuts are **Safety device** whose task is cutting the gas flow if abnormal pressure conditions appear, compared to the one set during calibration of the dedicated pressure switch.

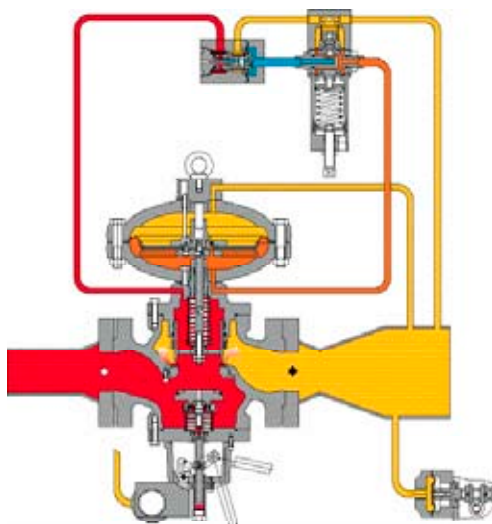

Fig.3

REFLUX 819 - With slam shuth SB

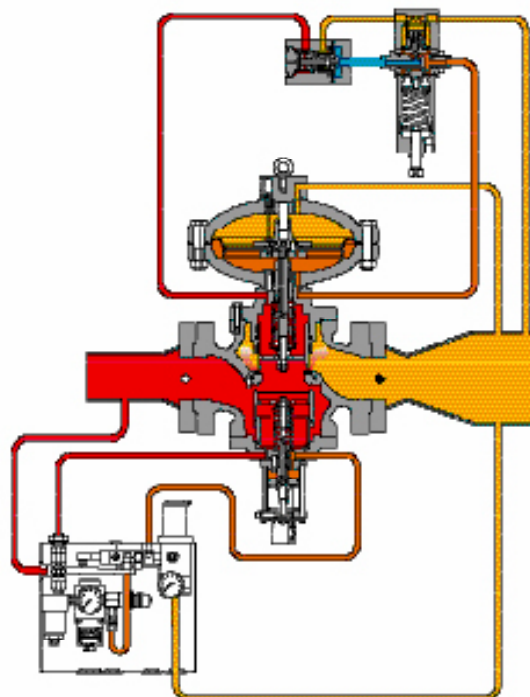

Fig.4

REFLUX 819 - With slam shuth HB

The calibration can be varied, according to the operating needs, in the ranges referred to in the table N.2, according to the model of pressure switch applied.

The slam shut device is equipped with a button for local manual control of the block operation.

The reset of the block device, for safety reasons, is exclusively manual and, inside the block device, a bypass device is provided, in order to make the reset operation easier.

The slam-shut device can be equipped with accessories of pneumatic or electromagnetic type allowing control, as well as with sensors (micro-switches) for the remote signaling of its tripping.

Pressure switch

MOD. SB	MIN.	MAX
102M	2.17 ÷ 40.61	2.17 ÷ 97.17
102MH	40.61 ÷ 79.77	2.17 ÷ 97.17
103M	2.17 ÷ 116.03	26.10 ÷ 333.58
103MH	116.03 ÷ 275.57	26.10 ÷ 333.58
104M	20.30 ÷ 261.06	203.05 ÷ 696.18
104MH	261.06 ÷ 594.65	203.05 ÷ 696.18
105M	29.00 ÷ 638.16	391.60 ÷ 1450.37
105MH	638.16 ÷ 1,305.33	391.60 ÷ 1450.37
MOD. HB		
103	5.80 - 98.62	18.85 - 159.54
104	13.77 - 319.08	145.03 - 456.86
105	36.25 - 725.18	362.59 - 1131.79
105/92	609.15 - 1131.29	797.70 - 1305.33
		Tab.2

Values in PSIG

The slam shut valve can be calibrated for pressure increase, **over pressure shut off (OPSO)** and/or for pressure drop, **under pressure shut off (UPS0)**.

The two intervention modes can be tuned independently, using the dedicated calibration springs: a spring for the intervention of maximum pressure and a second spring for the intervention of minimum pressure.

The choice between the two models - SB/82 and HB/97 - depends on the size of the regulator and on the maximum instantaneous flow rate to be provided.

In general, up to a diameter of DN 80 (3") included, the valve model SB/82 only is mounted; while, for greater sizes, it is necessary to assess whether it is suitable to mount the model HB/97 instead of model SB/82.

For in-depth assessments, please contact our technical and sales department.

The slam shut device incorporated in the regulators causes a reduction of the coefficients Cg and Kg equal to about 7% of the value of the basic regulator.

Monitor incorporated PM/819

The **MONITOR REGULATOR** is a safety accessory whose task is that of performing the functions of the service regulator in case of failure of the main regulator.

This is a regulator that is normally in fully open position during normal operation of the operating regulator.

It is generally installed following the gas flow direction, upstream of another pressure regulator that acts as OPERATING regulator

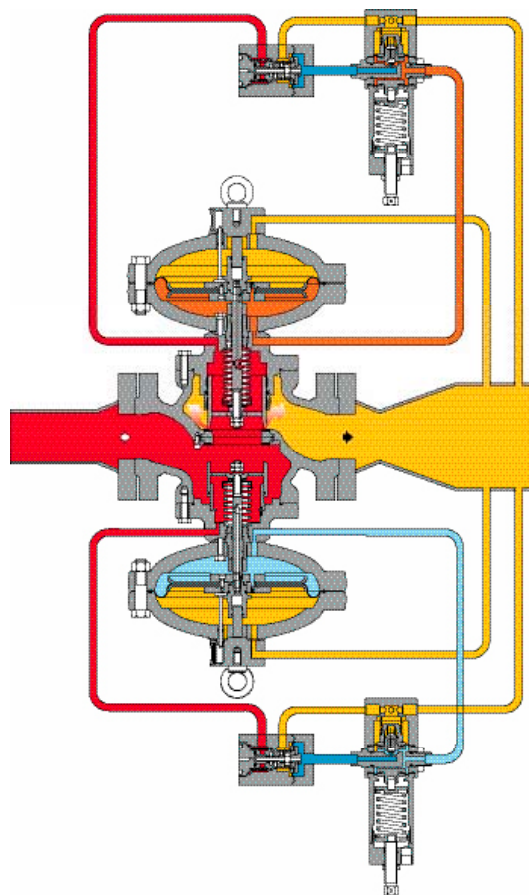

Fig.5

REFLUX 819 - With monitor incorporated

In this specific case, the Monitor **PM/819** is mounted on the same body of the operating regulator but it is provided with its own sealing seat, piloting system and an independent motorization.

The functional characteristics of the **Monitor PM/819** are the same of the basic regulator **REFLUX 819**

The assembly **REFLUX 819** with **Monitor PM/819** is characterized by equivalent coefficients C_g and K_G reduced by **7%** compared to those of the basic regulator.

This solution allows creating reduction lines featuring very small overall dimensions and lower pressure drops compared to the traditional solution of the two regulators installed in line.

In-line Monitor

In this solution, the Monitor regulator and Operating one are installed in series.

Fig. 6 represents the traditional solution where the monitor is usually installed upstream and the operating regulator is installed downstream (following the gas flow direction).

The Monitor regulator is set at a value that is slightly higher than the calibration set-point of the Operating regulator.

The equivalent coefficients C_g and K_g of the system are on average lower by 20% compared to the coefficients of the basic regulator (case with equal regulators having the same size).

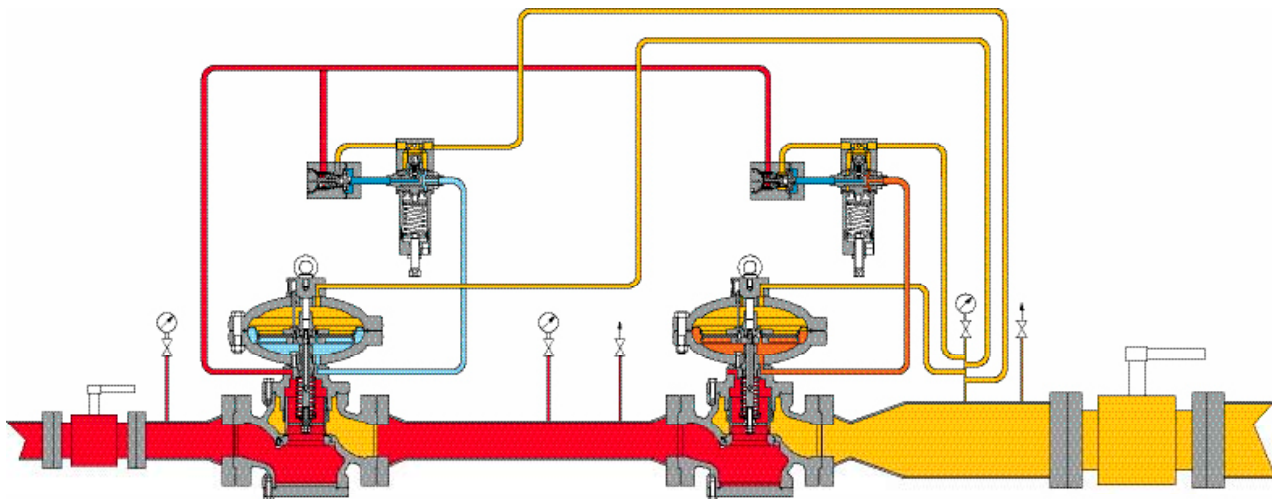

Fig.6

REFLUX 819 - Solution with in-line monitor

Optional

For the pressure regulators:

- Stroke limiters
- Devices for flow rate limitation
- Limit switches
- Position transmitters
- Steel fittings, single or dual sealing

For the pilot circuit

- M/A Accelerators
- R14/A/S Preregulator for the high pressure circuit ($P > \text{Psi } 174.5$ (12 bar))
- Heating cable for preheating pilot circuit
- Electrical Heater
- Supplementary Filter CF 14
- Dehydrating Filter CF 14/D
- Fluid Control 896, Pilots for modulation of pressure adjustment
- .../F.I.O. SMART unit for remote adjustment

Sizing of pressure Regulator

In general, the choice of a regulator is made based on the calculation of the flow rate determined by the use of formulas and on the flow rate coefficients (Cg or KG) as indicated by the EN 334 standard.

For the sizing of the involved regulators, kindly refer to our website: www.fiorentini.com/sizing.

For different gases and for natural gas with a different density than 0,61 shall be applied the correction coefficients resulting from the following formula:

$$F_c = \sqrt{\frac{175.8}{S \times (273.16 + t)}}$$

S = relative density to air
t = gas temperature [°C]

Correction factors FC		
Type of gas	Relative density (S)	Fc factor
Air	1.00	0.78
Propane	1.53	0.63
Butane	2.00	0.55
Nitrogen	0.97	0.79
Oxygen	1.14	0.73
Carbon dioxide	1.52	0.63

Tab.3

The chart shows the correction factors FC valid for above mentioned gas at 15 °C and to the declared relative density.

Flow rate conversion		
Stm ³ /h	x 0,94795	= Nm ³ /h

Tab.4

CAUTION:

In order to get optimal performance, to avoid premature erosion phenomena and to limit noise emissions, it is recommended to check that gas speed at the outlet flange does not exceed the values of the graph below.

The gas speed at the outlet flange may be calculated by means of the following formula:

$$V = 345.92 \times \frac{Q}{DN^2} \times \frac{1 - 0.002 \times Pd}{1 + Pd}$$

where:

- V** = gas speed in m/sec
- Q** = gas flow rate in Stm³/h
- DN** = nominal size of regulator in mm
- Pd** = outlet pressure in barg.

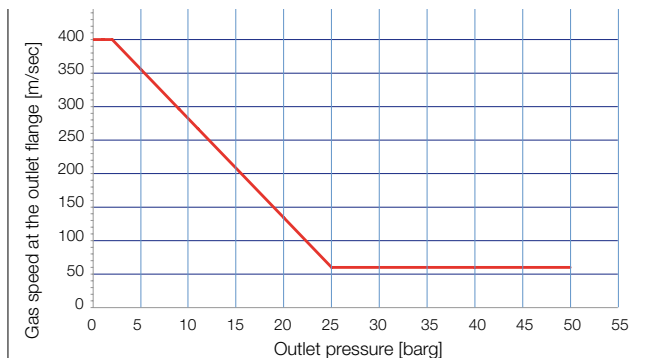

TYPICAL CONNECTION DIAGRAMS

The following examples are provided as a recommendation to get the best performance from the regulator **REFLUX 819**.

IN-LINE INSTALLATION

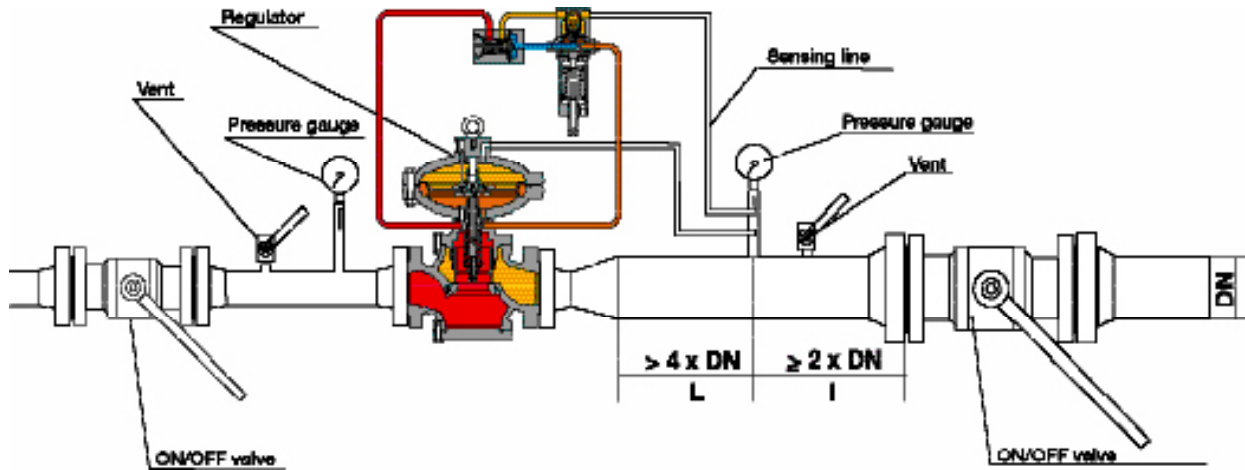
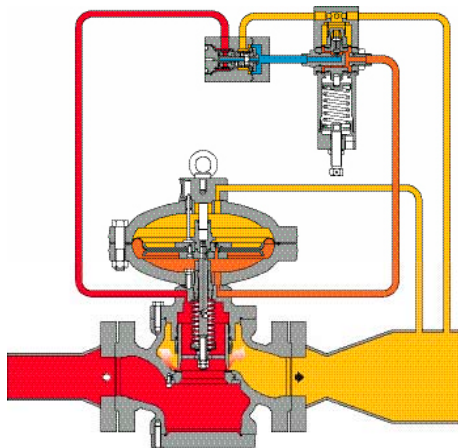

Fig.7

RECOMMENDED INSTALLATIONS



Standard position

Fig.8

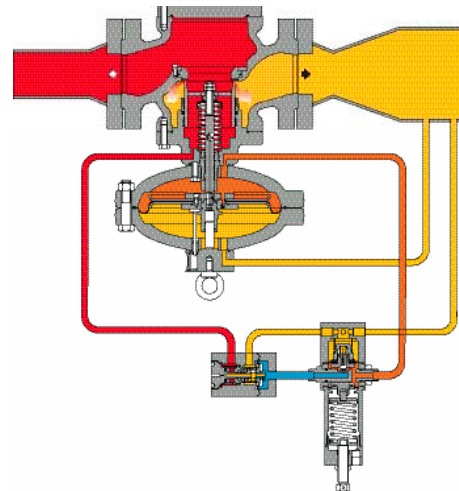

Upside down position

Fig.9

■ Inlet pressure
■ Outlet pressure

■ Motorization
■ Motorization Monitor

■ Control Feed
■ Pilot Feed

RECOMMENDED INSTALLATIONS

Regulator Reflex 819 with incorporated Monitor PM/819

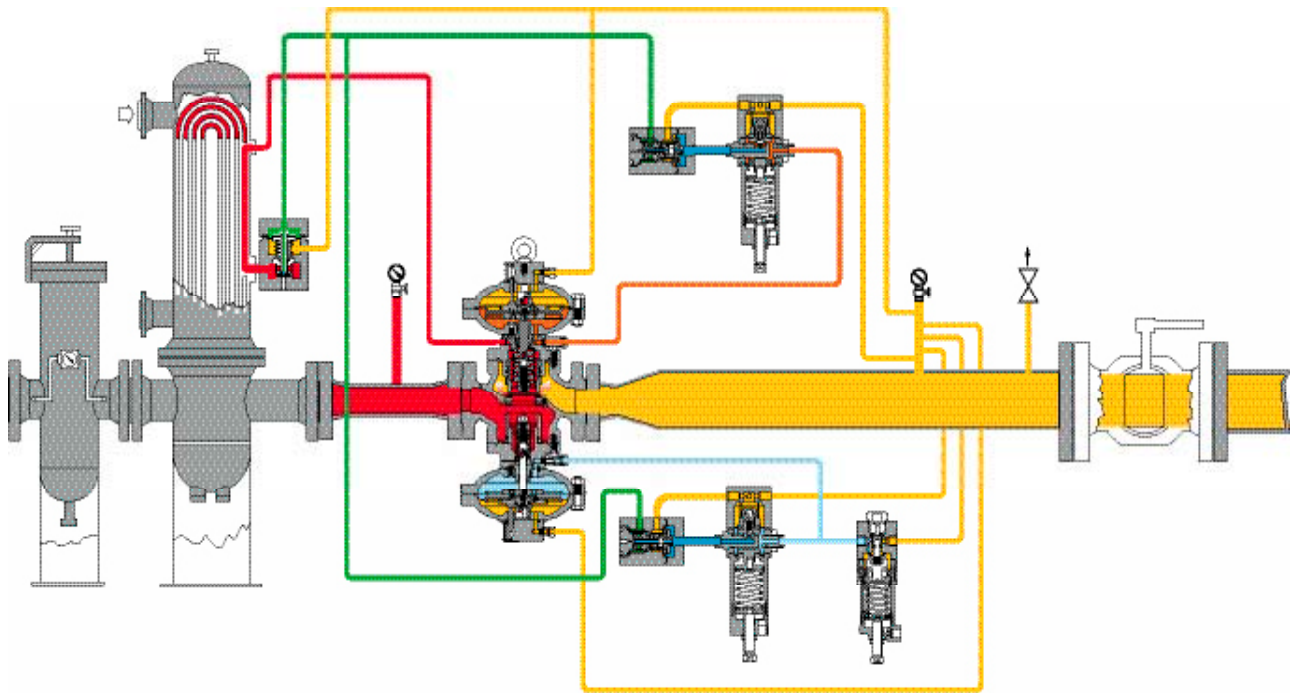

Slam Shut SBC 782 and Reflex 819 pressure regulator with incorporated slam shut device SB82

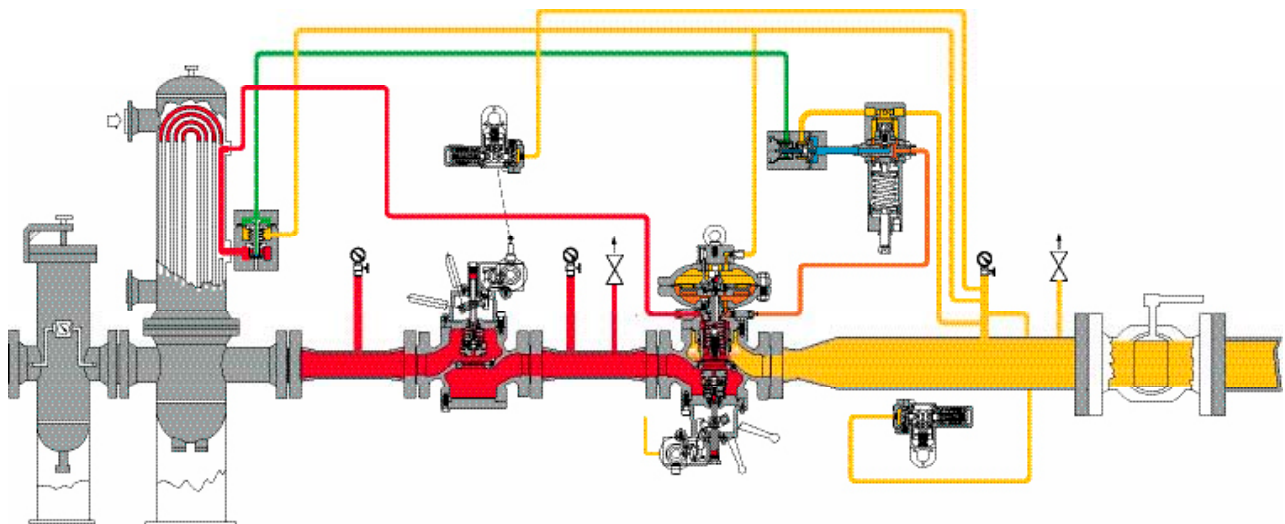

Monitor Reflex 819 with incorporated slum shut HB/97 and operating pressure regulator Reflex 819

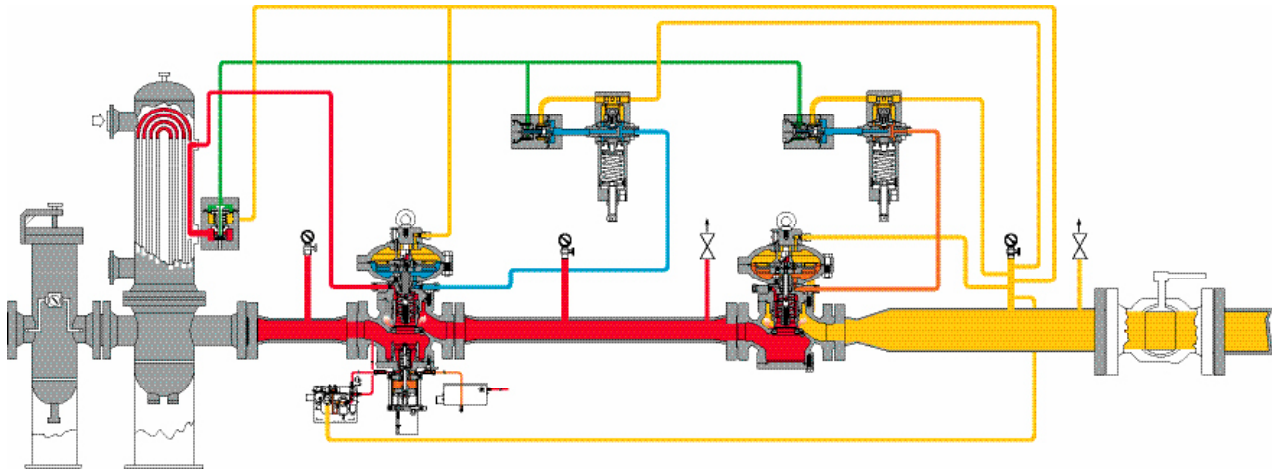

Fig.12

Pressure regulator operating monitor Reflex 819 and operating pressure regulator Reflex 819

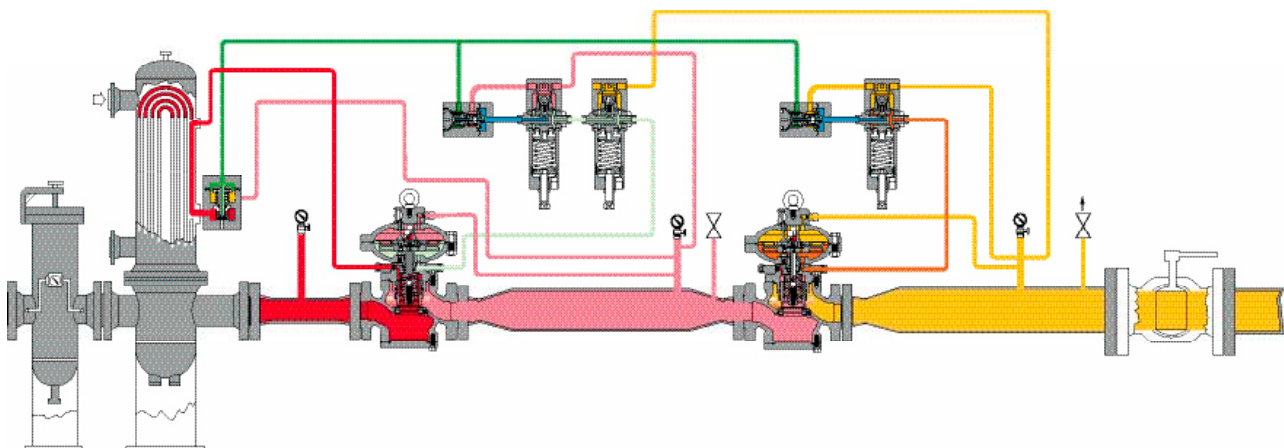

Fig.13

REFLUX 819

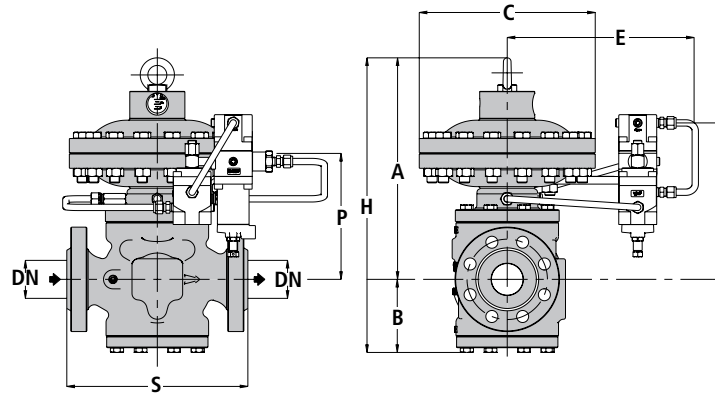

Fig.14

Dimensions								
Inches	1"	2"	3"	4"	6"	8"	10"	12"
S - Ansi 150/PN 16	7.25	10.5	11.75	13.88	17.75	21.38	26.5	29.01
S - Ansi 300	7.75	11.25	12.5	14.5	18.62	22.38	27.88	30.51
S - Ansi 600	8.25	13.78	13.25	15.5	20	24	29.62	32.24
A	12.60	5.11	16.92	19.29	25.60	29.52	31.49	37.40
B	3.93	10.95	5.9	7.48	8.85	10.43	13.38	14.67
C	10.94	6.30	14.17	14.17	20.07	20.07	24	28.27
E	12.20	12.20	12.60	12.59	16.53	16.53	18.5	19.68
F	10.24	16.92	13.77	14.96	16.14	18.11	22	25.39
H	16.53	7.87	22.83	26.77	34.44	39.96	48.81	51.18
P	6.69	200	10.23	11.41	12.59	14.56	19.68	24.80
								Tab.5

Pneumatic fittings; 1/4"NPT

Dimensions S according to EN 334 and IEC 534-3

Weight in Lbs								
Ansi 150/PN 16	97	134.4	231.5	321.8	679	899.5	1,984	2,543.1
Ansi 300	99.2	136.7	240.3	344	760.5	1,036	2,094	3,108.5
Ansi 600	101.4	141	246.9	363.7	793.6	1,091	2,204	3,284.9
								Tab.6

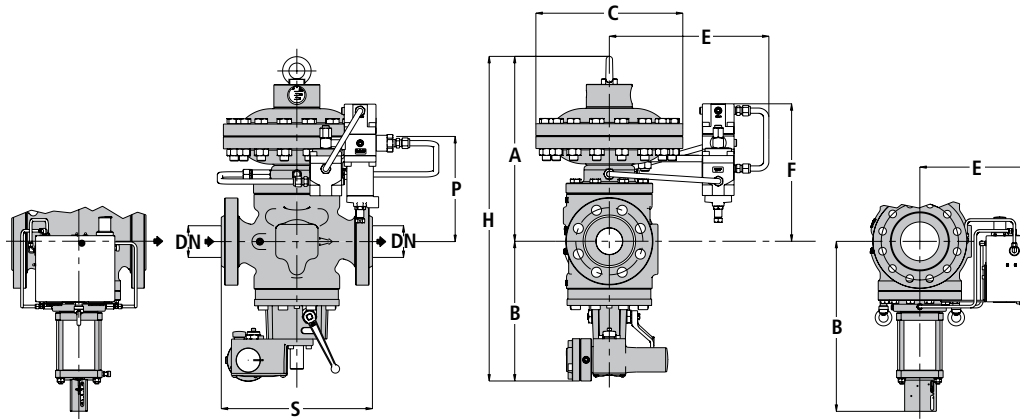
REFLUX 819 + SB/82 + HB/97

Fig.15
Dimensions

Inches	1"	2"	3"	4"	6"	8"	10"	12"				
S - Ansi 150/PN 16	7.25	10	11.75	13.88	17.75	21.38	26.5		29.01*			
S - Ansi 300	7.75	10.5	12.5	14.5	18.62	22.38	27.88		30.51*			
S - Ansi 600	8.25	11.25	13.25	15.5	20	24	29.62		32.24*			
A	12.59	13.77	16.92	19.29	25.59	29.52	31.49		36.53*			
B	8.46	9.44	10.62	11.81	20.39*	14.76	25.39*	17.71	27.04*	20.86	31.33*	37.00*
C	10.94	10.94	14.17	14.17	20.07	20.07	24.01		28,24*			
E	12.20	12.20	12.59	12.59	14.09*	16.53	16.14*	16.53	17.51*	18.5	20.07*	20.96*
F	10.23	11.41	13.77	14.96		16.14	18.11	22.04		25.35*		
H	21.06	23.22	27.55	31.1		40.35	47.24	52.36		73.22*		
P	6.69	7.87	10.23	11.41		12.59	14.56	19.68		24.80*		

Tab.7

Pneumatic fittings: 1/4 NPT

* Weight & dimensions with HB/97.

Dimensions S according to EN 334 and IEC 534-3.

Weight in Lbs

Ansi 150/PN 16	116.8	156.5	253.5	352.7	705.5	1,014	2,094		3,560.5*			
Ansi 300	121.2	161	269	377	394.6*	804.5	895*	1,157	1,230.1*	2,204	2,378.7*	3,725.8*
Ansi 600	123.4	165.5	275.5	397	434.3*	837.7	952.3*	1,212.5	1,287.4*	2,314	2,422.8*	3,902.2*

Tab.8

REFLUX 819 + PM/819

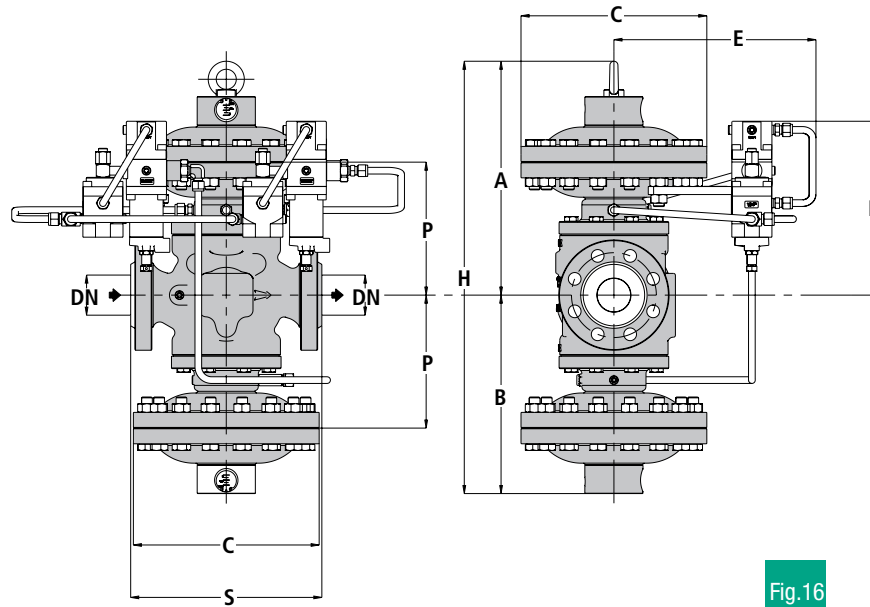

Fig.16

Dimensions							
Inches	1"	2"	3"	4"	6"	8"	10"
S - Ansi 150/PN 16	7.25	10	11.75	13.88	17.75	21.38	26.5
S - Ansi 300	7.75	10.5	12.5	14.5	18.62	22.38	27.88
S - Ansi 600	8.25	11.25	13.25	15.5	20	24	29.62
A	12.59	13.77	16.92	19.29	25.59	29.52	31.49
B	12.59	13.77	16.92	19.29	25.59	29.52	31.49
C	10.94	10.94	14.17	14.17	20.07	20.07	24.01
E	12.2	12.2	12.59	12.59	16.53	16.53	18.5
F	12.23	11.41	13.77	14.96	16.14	18.11	22.04
H	25.19	27.55	33.85	38.58	51.18	59.05	63
P	6.69	7.87	10.23	11.41	12.59	14.56	19.68
							Tab.9

Pneumatic fittings: 1/4" NPT

Dimensions S according to EN 334 and IEC 534-3

Weight in Lbs							
Ansi 150/PN 16	185	231.5	296.7	540	1,139.7	1,477	3,086.5
Ansi 300	187.3	233.7	405.7	562.2	1,221.5	1,611.5	3,196.7
Ansi 600	189.5	238	412.2	582	1,254.5	1,666.7	3,307
							Tab.10

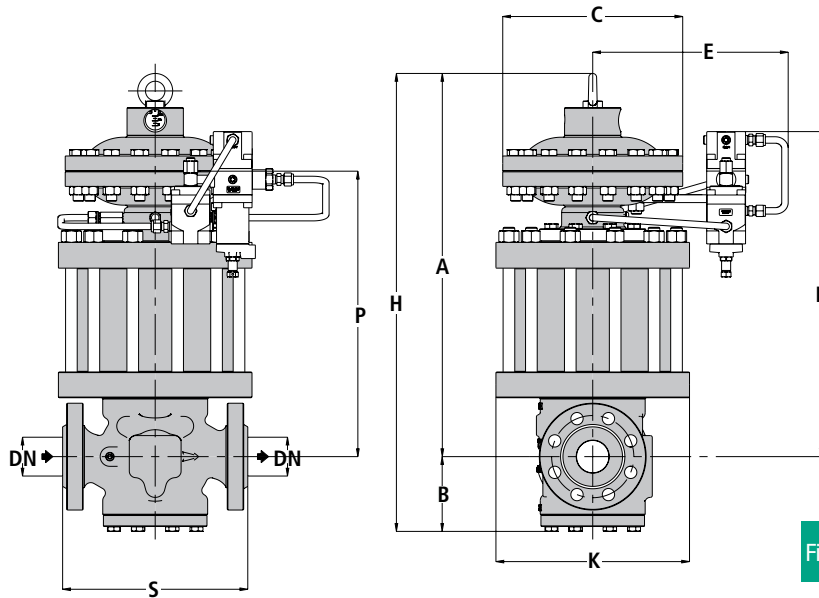
REFLUX 819 + DB/819

Fig.17
Dimensions

Inches	1"	2"	3"	4"	6"	8"	10"	12"
S - Ansi 150/PN 16	7.25	10	11.75	13.88	17.75	21.38	26.5	29.01
S - Ansi 300	7.75	10.5	12.5	14.5	18.62	22.38	27.88	30.51
S - Ansi 600	8.25	11.25	13.25	15.5	20	24	29.62	32.24
A	20.47	22.63	27.55	31.49	36.81	42.71	51.18	59.25
B	3.93	5.11	5.9	7.48	8.85	10.43	13.38	14.64
C	10.94	10.94	14.17	14.17	20	20	24	28.26
E	12.2	12.2	12.59	12.59	16.53	16.53	18.5	13.58
F	16.73	19.48	24.21	26.37	31.29	35.23	4.33	48.63
H	24.4	27.75	33.46	38.97	45.66	53.14	64.56	73.99
P	14.56	15.74	19.88	23	27.16	30.31	39.37	47.44
K	8.66	11.81	13	15.35	18.89	23.42	27.36	29.33

Tab.11
Pneumatic fittings: 1/4 NPT

Dimensions S according to EN 334 and IEC 534-3

Weight in Lbs

Ansi 150/PN 16	154.3	277.7	430	573.2	1,245.7	1,841	2,822	2035
Ansi 300	158.73	282.2	449.7	673.1	1,340	2,039	3,042.5	1230
Ansi 600	161	286.6	456.3	657	1,411	2,093.5	3,152.5	2310

Tab.12

REFLUX 819 + DB/819+SB/82+HB/97

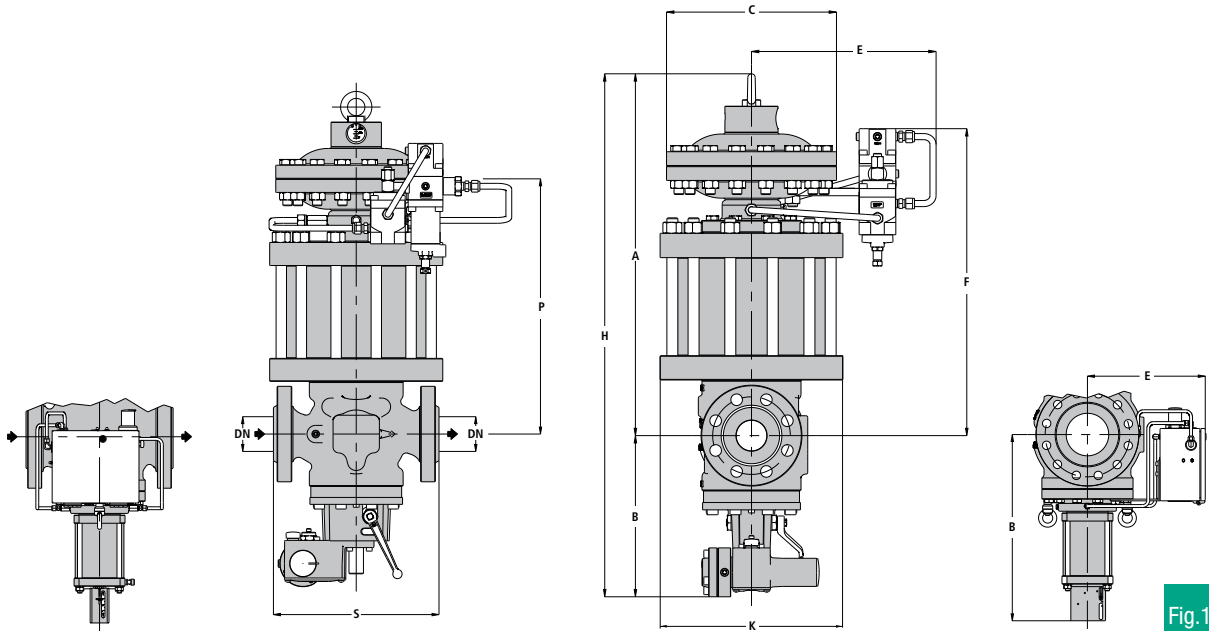

Fig.18

Dimensions

Inches	1"	2"	3"	4"	6"	8"	10"	12"				
S - Ansi 150/PN 16	7.25	10	11.75	13.88	17.75	21.38	26.5	29.01*				
S - Ansi 300	7.75	10.5	12.5	14.5	18.62	22.38	27.88	30.51*				
S - Ansi 600	8.25	11.25	13.25	15.5	20	24	29.62	32.24*				
A	20.47	22.63	27.55	31.49	36.81	42.71	51.18	59.25*				
B	8.46	9.44	10.62	11.81	20.39*	14.76	25.39*	17.71	27*	20.86	31.33*	37.00*
C	10.94	10.94	14.17	14.17	20	20	24	28.26*				
E	12.2	12.2	12.59	12.59	14.09*	16.53	16.14*	16.53	17.51*	18.5	20.07*	20.86*
F	16.73	19.48	24.21	26.37	31.29	34.05	43.30	48.03*				
H	28.93	32.08	38.18	43.3	51.57	60.43	72.05	96.25*				
P	14.56	15.74	19.88	22.63	27.16	30.31	39.37	47.44*				
K	8.66	11.81	13	15.35	18.89	23.42	27.36	29.33*				

Tab.13

Pneumatic fittings: 1/4" NPT

* Weight & dimensions with HB/97.

Dimensions S according to EN 334 and IEC 534-3.

Weight in Lbs

Ansi 150/PN 16	174.16	300	452	604*	1,272*	1,955.5*	2,932	5,103.6*				
Ansi 300	180.77	306.5	478.5	670.5*	701.5*	1,384.5	1,457*	2,179.5*	2,217.9*	3,152.5	3,882.3*	5,518.2*
Ansi 600	183	311	485	690.5*	727.5*	1,455	1,514.5*	2,275.1*	2,275.1*	3,263	3,926.4*	5,709.3*

Tab.14

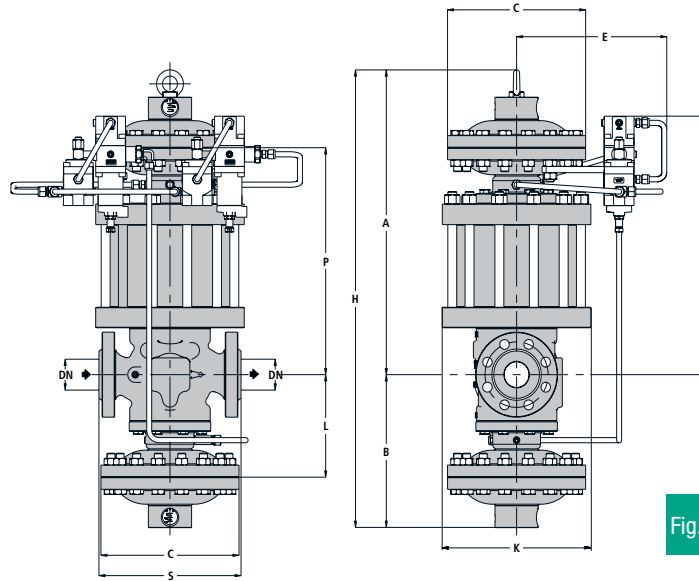
REFLUX 819 + DB/819 + PM/819

Fig.19

Dimensions							
Inches	1"	2"	3"	4"	6"	8"	10"
S - Ansi 150/PN 16	7.25	10	11.75	13.88	17.75	21.38	26.5
S - Ansi 300	7.75	10.5	12.5	14.5	18.62	22.38	27.88
S - Ansi 600	8.25	11.25	13.25	15.5	20	24	29.62
A	20.47	22.63	27.55	31.49	36.81	42.71	71.20
B	12.59	13.77	16.92	19.29	25.59	29.52	44.20
C	10.94	10.94	14.17	14.17	20	20	24
E	12.2	12.2	12.59	12.59	16.53	16.53	18.5
F	16.73	19.48	24.21	23.37	31.29	35.23	43.3
H	33.07	36.41	44.48	50.78	62.4	72.24	82.67
P	14.56	15.74	19.88	22.63	27.16	30.31	39.37
K	8.66	11.81	13	15.35	18.89	23.42	27.36

Tab.15

Pneumatic fittings: 1/4" NPT

Dimensions S according to EN 334 and IEC 534-3.

Weight in Lbs							
Ansi 150/PN 16	242.5	374.8	595.3	791.5	1,706.5	2,418.7	3,924.5
Ansi 300	247	379.2	588.5	855.4	1,726.2	2,612.5	4,144.7
Ansi 600	249.2	383.7	595.2	875.5	1,796.7	2,667.5	4,255

Tab.16

www.florentini.com

The data are not binding. We reserve the right to make changes without prior notice.

